

NAPOLEON

Ball Joint Mirror (Square)

Universal for both sides
AM-10 (10mm Clockwise)
 Aluminum die-cast/ Clear mirror
AMB-10 (10mm Clockwise)
 Aluminum die-cast/ Blue mirror

Height adjustment spacer 



Curved surface mirror to show the wide rear-view.



Easy angle adjustment by the ball joint system. (360° revolvable)

*need angle adjustment when you set this on the left.

Ball Joint Mirror (Round)

Universal for both sides
AW-10 (10mm Clockwise)
 Aluminum die-cast/ Clear mirror
AWB-10 (10mm Clockwise)
 Aluminum die-cast/ Blue mirror

Height adjustment spacer 



Curved surface mirror to show the wide rear-view.



Easy angle adjustment by the ball joint system. (360° revolvable)

*need angle adjustment when you set this on the left.

Custom Round Mirror

R for right only, L for left only.
ARB-10R (10mm Clockwise)
ARB-10L (10mm Clockwise)
 Blue mirror

stainless-steel head



Curved surface mirror to show the wide rear-view.

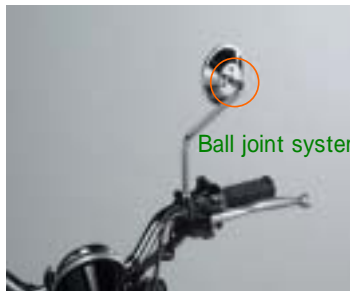

Ball joint system

chrome finished stay

Custom Square Mirror

R for right only, L for left only.
AC-10R (10mm Clockwise)
AC-10L (10mm Clockwise)
 Clear mirror
ACB-10R (10mm Clockwise)
ACB-10L (10mm Clockwise)
 Blue mirror

stainless-steel head



Curved surface mirror to show the wide rear-view.



Ball joint system

chrome finished stay

Slide Mirror/ Slide Mirror Short

Universal for both sides
AA-10 (with 10mm Clockwise/ Counterclockwise spacer)
 16cm stay, Chrome finished
AA-10S (with 10mm Clockwise/ Counterclockwise spacer)
 12cm stay, Chrome finished

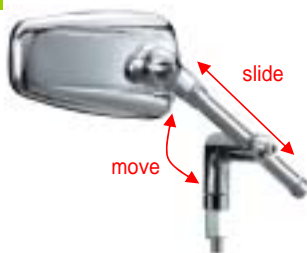

Good looking custom
 For Big scooter and
 Super Sports!

Low down looks



Street Mirror

Universal for both sides
AN-10 (10mm Clockwise)
AN-10Y (10mm Counterclockwise)
 Chrome finished

Curved surface mirror to show the wide rear-view.

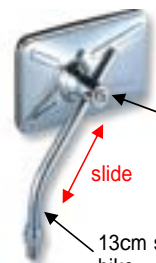

easy to adjust the mirror head position by one screw.

13cm stay fits for a custom bike.

Small head to make the look fashionable.



NAPOLEON

AZ Mirror

Universal for both sides

AZ-101-8 (8mm Clockwise)

AZ-101-8Y (8mm Counterclockwise)

AZ-101-10 (10mm Clockwise)

AZ-101-10Y (10mm Counterclockwise)

Chrome finished

AZ-104-8 (8mm Clockwise)

AZ-104-10 (10mm Clockwise)

Black

easy to adjust the mirror head position by one screw

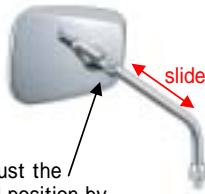

No.1 Sales

AZ 2 Mirror

Universal for both sides

AZ -101-10 Chrome finished (10mm Clockwise)

AZ -104-10 Black (10mm Clockwise)

one size bigger than AZ mirror.



Best match for big naked bike!



Classical Mirror

Universal for both sides

AB-8 (8mm Clockwise)

AB-10 (10mm Clockwise)

Chrome finished

Oval type mirror produces your motorcycle to a classic style.

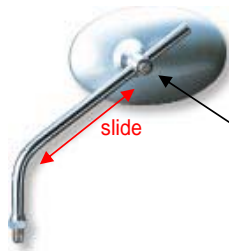

easy to adjust the mirror head position by one screw

Trad Mirror

Universal for both sides

AT-8 (8mm Clockwise)

AT-8Y (8mm Counterclockwise)

AT-10 (10mm Clockwise)

AT-10Y (10mm Counterclockwise)

stainless-steel head

chrome finished stay

Curved surface mirror to show the wide rear-view.

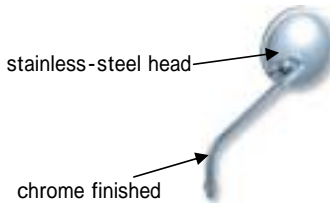

Baren Classic

Universal for both sides

APB-10 Chrome finished

(with 10mm Clockwise/Counterclockwise bolt)

APB-104-10 Black

(with 10mm Clockwise/Counterclockwise bolt)

Popular for the Big Scooter users!



Cast stay & Oval design create push & sense of speed.

Easy adjustment by the Retractable stay!



*If this hits the reserver tank, use an adapter (HM-10, B-10, BM-10).

8 steps, 360 ° revolving.

Baren Classic Blue

Universal for both sides

APB-10B Chrome finished

(with 10mm Clockwise/Counterclockwise bolt)

Blue mirror version of Baren Classic!!

Cast stay & Oval design create push & sense of speed.

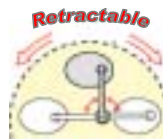

Easy adjustment by the Retractable stay!



*If this hits the reserver tank, use an adapter (HM-10, B-10, BM-10).

8 steps, 360 ° revolving.

NAPOLEON

Baren AA

Universal for both sides

APA-10 Chrome finished
(with 10mm Clockwise/Counterclockwise bolt)

Sharp and Cool!
Slide mirror head

Easy adjustment by
the Retractable stay!

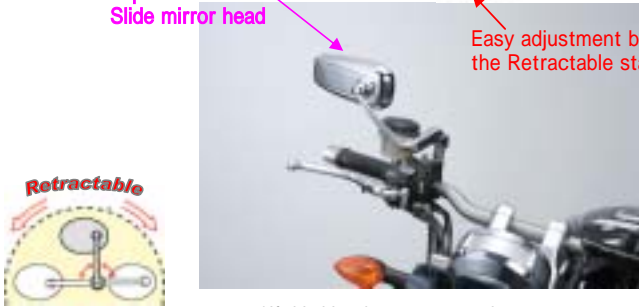

8 steps, 360° revolving.

*If this hits the reserver tank,
use an adapter (HM-10, B-10, BM-10).

Baren T.T.

Universal for both sides

APT-101 Chrome finished
(with 10mm Clockwise/Counterclockwise bolt)

APT-104 Black
(with 10mm Clockwise/Counterclockwise bolt)

"Traditional form"

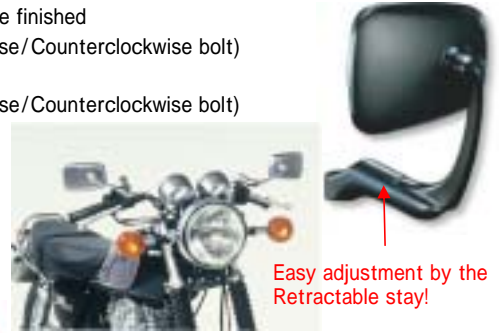

Easy adjustment by the
Retractable stay!

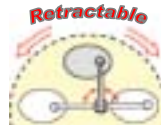

8 steps, 360° revolving.

*If this hits the reserver tank,
use an adapter (HM-10, B-10, BM-10).

"Matches for classic style,
European style dress-up!"

Baren

Universal for both sides (Fit only on bar-end)

AP-101 Chrome finished

AP-104 Black

European type:
set at the end of the handle grip.



8 steps, 360° revolving.

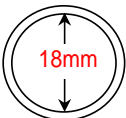

Easy setting by one bolt!
Adopted for Ducati!

*Only for 18mm handle's inner diameter.

Lute Mirror

Universal for both sides

APE-101-10 Chrome finished
(10mm Clockwise)

APE-104-10 Black
(10mm Clockwise)

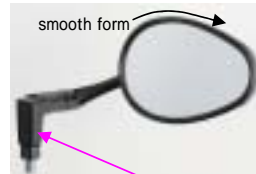

smooth form



no steps, endless revolving.

Safety feature "Turner"
absorbs the shock.



Wider mirror area!



Naked Mirror

Universal for both sides

AG-101 Chrome finished stay
(10mm Clockwise)

AG-104 Black
(10mm Clockwise)

Stainless head

Easy to adjust the stay angle
and mirror position!

Safety feature "Turner" absorbs the shock.

Low type of the Spartan
shape stands out on the
naked model motorcycle!



Blade Stay Mirror

Universal for both sides

AGB-101-10 Chrome finished
(10mm Clockwise)

AGB-104-10 Black
(10mm Clockwise)

air-flow controlled design



Blade-designed stay
for aerodynamic!

Safety feature "Turner"



NAPOLEON

Napoleon Stingray Mirror

Universal for both sides

APO-101-10 Chrome finished
(10mm Clockwise)

Fits for any motorcycle



Safety feature "Turner" absorbs the shock.

Super Mirror

L for left only, R for right only

AQ-8L (8mm Clockwise)
AQ-8R (8mm Clockwise)
AQ-10L (10mm Clockwise)
AQ-10R (10mm Clockwise)
Black

Square mirror creates the high efficient view.

Long Seller

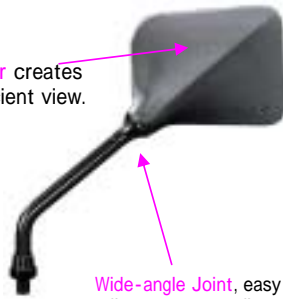

Wide-angle Joint, easy adjustment according to your riding position.

Radical Mirror EX

Universal for both sides

AUE-8 (8mm Clockwise)
AUE-10 (10mm Clockwise)
Black

Bigger mirror size compared to the Radical mirror.

slide

Universal Joint absorbs the shock in case of accident or contact.

Your arm doesn't touch when you stand up!



Napoleon Motarz-Mirror

Universal for both sides

ARX-8 (with 8mm Clockwise/
Counterclockwise bolt)
ARX-10 (with 10mm Clockwise/
Counterclockwise bolt)
Chrome finished

Compact head shape!

Universal Joint absorbs the shock in case of accident or contact.

Curved surface mirror to show the wide rear-view.

Designed for Motard customs!



Radical Mirror

Universal for both sides

AU-8 (8mm Clockwise)
AU-10 (10mm Clockwise)
Black

slide

Universal Joint absorbs the shock in case of accident or contact.

Joint boots protect the joint from rain and dust.

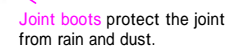
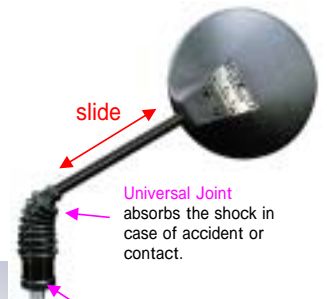

NAPOLEON

Radical Mirror

Universal for both sides

AU-101-8 (8mm Clockwise)

AU-101-10 (10mm Clockwise)

Chrome finished



Cross

L for left only, R for right only

AX-10L (10mm Clockwise)

AX-10R (10mm Clockwise)

Black

Wide square mirror creates the high efficient view.



Bigger mirror head!



Wide-angle Joint, easy adjustment according to your riding position.

Cross 2

L for left only, R for right only

AJ-8L (8mm Clockwise)

AJ-8R (8mm Clockwise)

AJ-10L (10mm Clockwise)

AJ-10R (10mm Clockwise)

Black

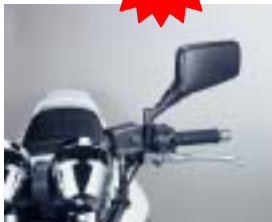

Safety feature "Turner" absorbs the shock.

Cross 3 (Blue Mirror)

Universal for both sides

AYB-8 (8mm Clockwise)

AYB-10 (10mm Clockwise)

Black

Blue mirror with the "Napoleon" logo!!



Safety feature "Turner" absorbs the shock.

Makes your motorcycle look more sharp!!

NAPOLEON

Cross 2 / Optics

L for left only, R for right only
AJS-10L (10mm Clockwise)
AJS-10R (10mm Clockwise)
 Black



"Optics mirror" cuts only the dazzling light to your eyes.



Optics

Normal Mirror

Safety feature "Turner" absorbs the shock.

AZ Mirror / Optics

Universal for both sides
AZS-101-10 Chrome finished (10mm Clockwise)
AZS-104-10 Black (10mm Clockwise)



"Optics mirror" cuts only the dazzling light to your eyes.



Optics

Normal Mirror

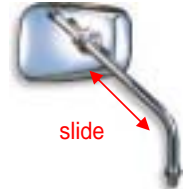

slide

OPTICS

Glare-proof Mirror

We produced successful production called "OPTICS" with the optical company "HOYA" to reduce the dazzling light reflection: 450-650nm (nano meter). Differing from other similar mirrors, "OPTICS" can cut the only light that human feels glaring. Riders can see more clear and sharp view due to the less brightness while the night view is the same definition.



Optics



Normal Mirror

System Mirror Series

You can arrange the mirror parts matching with mirror heads, stays, stay holders as you like. In addition, you can use them for repairs.

Matching Example:1

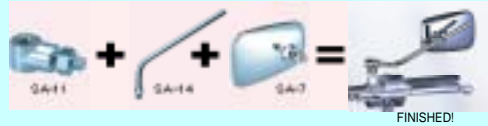

FINISHED!

Matching Example:2

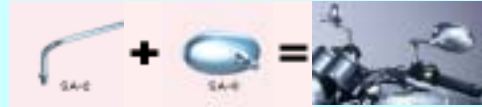

FINISHED!

Wing Stay 10R / 10L / 10RY

Wing Stay 10R
SA-1 (10mm Clockwise) Stay diameter 9.8

Wing Stay 10L
SA-2 (10mm Clockwise) 3 dimensional stay makes your motorcycle look smart and sporty!

Wing Stay 10RY
SA-17 (10mm Counterclockwise) Example: SA-2+SA-8
 All Chrome finished



30cm / 40cm / 50cm Mirror Stay

30cm Mirror Stay
SA-3 (10mm Clockwise) Stay diameter 9.8

40cm Mirror Stay
SA-4 (10mm Clockwise)

50cm Mirror Stay
SA-5 (10mm Clockwise)
 All Chrome finished

Long stays have many possibilities for customizing!



NAPOLEON

Stay Holder

SA-6 (for 22mm & 25mm handle diameter)
 Chrome finished
 Hexagon wrench included



*Adaptor to attach the mirror stay to handle.
 *You can attach this anywhere on the handle.
 *For 10mm stay.

AZ head / AB head / AD head / AN head

AZ Head (Universal for both sides) Only for Stay diameter 9.8
SA-7: Chrome finished
 AB Head (Universal for both sides)
SA-8: Chrome finished
 AD Head (Universal for both sides)
SA-9: Stainless
 AN Head (Universal for both sides)
SA-10: Chrome finished



All model with hex wrench

Short Stay / 22cm Stay

Short Stay (Universal for both sides) Stay diameter 9.8
SA-13 (10mm Clockwise)

22cm Stay

SA-14 22cm Mirror Stay 10
 (10mm Clockwise)

SA-15 22cm Mirror Stay 8
 (8mm Clockwise)

SA-16 22cm Mirror Stay 10Y
 (10mm Counterclockwise)

All Chrome finished

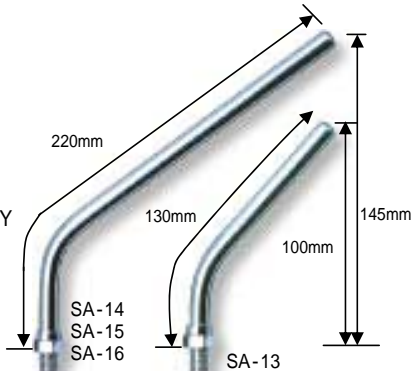

Right Angle Stay Adapter

SA-11
 Chrome finished

*Adaptor to change the direction of the mirror stay.
 *Possible to match with the Stay Holder (SA-6)
 *Screw diameter (bolt & nut): 10mm



Stay Boots (2pcs)

SA-12

*Protect the connection from dust
 *Suitable for dress-up by covering the screw adapter



「Reference of Screw diameter to connect Mirror」
 Page:

NAPOLEON

M10 Mirror Bolt Cap

BC-10 Black
BCM-10 Chrome finished
 (2 pcs/set)

*Decoration cap to cover the hexagon hole of 10mm mirror bolt.
 *Best fit for "Baren Mirror" Series bolt!



Mirror Adapter for Harley Davidson

G-1 Black
 (2 pcs/set)



*Adapter to match any kind of mirrors to the Harley Davidson.
 *You can use OE wipers as originally installed.
 *ONLY for 10mm clockwise universal mirror.

Mirror Adapter for BMW

G-2 Black
 (2 pcs/set)



*Adapter to match any kind of mirrors to the handle mount type of BMW.
 *Matches with R1200GS, K1200R and HP2.
 *ONLY for 10mm clockwise universal mirror.
 *Turner feature equipped.

Mirror Spacer

B-10 Black
 (2 pcs/set)
BM-10 Chrome finished
 (2 pcs/set)

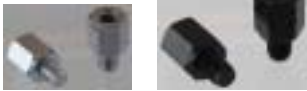

*Use to adjust the mirror height (20mm up)
 *Screw diameter (bolt&nut) is 10mm clockwise.

Part No.	Color	Mirror Screw Diameter → Fixing Screw Diameter	Height (mm)
B-10	Black	10mm Clockwise → 10mm Clockwise	20
BM-10	Chrome finished	10mm Clockwise → 10mm Clockwise	20

Mirror Adapter

All Kinds
 (2 pcs/set) Height: 20mm



*Two choices for your motorcycle: Black and Chrome finished.
 *Use when the screw direction and diameter do not fit.

<Attention>
 *Adapters match with all mirrors except Fairing Mirror and Baren (AP-101/104) Mirror.
 *Fixing screw caliber is for connection to your motorcycle, not for mirror dumper that some motorcycles have.
 *One is the adapter, another is the spacer to adjust the height.

Mismatch the screw direction (for Clockwise screw)

Part No.	Color	Mirror Screw Diameter → Fixing Screw Diameter
CM-1	Black	10mm Clockwise → 10mm Counterclockwise
CM-2	Chrome finished	10mm Clockwise → 10mm Counterclockwise
CM-3	Black	10mm Counterclockwise → 10mm Clockwise
CM-4	Chrome finished	10mm Counterclockwise → 10mm Clockwise

Mismatch the screw direction (for Counterclockwise)

Part No.	Color	Mirror Screw Diameter → Fixing Screw Diameter
CM-5	Black	10mm Counterclockwise → 10mm Clockwise
CM-6	Chrome finished	10mm Counterclockwise → 10mm Clockwise
CM-7	Black	10mm Clockwise → 10mm Counterclockwise
CM-8	Chrome finished	10mm Clockwise → 10mm Counterclockwise

Mismatch the screw diameter

Part No.	Color	Mirror Screw Diameter → Fixing Screw Diameter
CM-9	Black	10mm Clockwise → 8mm Counterclockwise
CM-10	Chrome finished	10mm Clockwise → 8mm Counterclockwise
CM-11	Black	10mm Counterclockwise → 8mm Clockwise
CM-12	Chrome finished	10mm Counterclockwise → 8mm Clockwise
CM-13	Black	10mm Clockwise → 8mm Counterclockwise
CM-14	Chrome finished	10mm Clockwise → 8mm Counterclockwise
CM-15	Black	10mm Counterclockwise → 8mm Clockwise
CM-16	Chrome finished	10mm Counterclockwise → 8mm Clockwise

Straight Turner

T-1/T-3/T-5/T-7/T-9/T-11
 Black
 (2 pcs/set)

T-2/T-4/T-6/T-8/T-10/T-12
 Chrome finished
 (2 pcs/set)



*Absorbs the shock from the contact when set between motorcycle and mirror.

Part No.	Product Name	Color	Mirror Screw Diameter → Fixing Screw Diameter
T-1	Straight Turner	Black	10mm Clockwise → 10mm Clockwise
T-2	Straight Turner	Chrome finished	10mm Clockwise → 10mm Clockwise
T-3	Straight Turner	Black	8mm Clockwise → 8mm Clockwise
T-4	Straight Turner	Chrome finished	8mm Clockwise → 8mm Clockwise
T-5	Straight Turner for covering screw diameter	Black	10mm Clockwise → 8mm Clockwise
T-6	Straight Turner for covering screw diameter	Chrome finished	10mm Clockwise → 8mm Clockwise
T-7	Counterclockwise Straight Turner	Black	10mm Clockwise → 10mm Counterclockwise
T-8	Counterclockwise Straight Turner	Chrome finished	10mm Clockwise → 10mm Counterclockwise
T-9	Counterclockwise Straight Turner	Black	10mm Counterclockwise → 10mm Clockwise
T-10	Counterclockwise Straight Turner for covering screw diameter	Chrome finished	10mm Clockwise → 10mm Counterclockwise
T-11	Counterclockwise Straight Turner for covering screw diameter	Black	10mm Clockwise → 10mm Counterclockwise
T-12	Counterclockwise Straight Turner	Chrome finished	10mm Clockwise → 10mm Counterclockwise

HONDA			
Model	mm	Model	mm
AX-1	*2	Julio	8
CB125T		Giorno/Giorno Crea. Giorcub	8
CB1300SF/1000SF/750/400SF*3	10	Joker50/90	10
CD series	10	Silver Wing400/600	*3 10
CL400	10	Steed 400/600	10
CRM250	*2	Spacy 100/125	*1*6 8
CRM50/80(for rear brake drum type)	8	Zoomer	*5 8
CRM50/80(for rear disc brake type)	10	Super Cub60/70/90/100/ Presto Cub, Little Cub	*5 8
FTR223	*2	Solo	8
GB250	10	Tact	8
PS250	*3	Dio series	*5*6 8
SL230	*2	Degree	*2 10
TLM220R	*2	Today	*6 8
VRX Roadster	10	TRANSALP	*2 10
VTR250	*3	Dream50	10
VTX	10	Night Hawk	10
V Twin Magna	*3	Bite	8
XL230	*2	Foresight	*1*6 8
XLR	*2	Varadero	*2 10
XR50/100	*2*5	Forza	*3 10
XR230	*2	Fusion	*3 10
XR400/XR250/XR250 Motard	*2	Benly series	8
X-4	10	Hornet250/600/900	*3 10
X-11	10	Magna50	10
Africa Twin	*2	Monkey / Gorilla	*5 8
Ape50/100	*5	Monkey R/RT/Baja	10
Crea Scoopy series	*5	Lead50/90	*6 8
Jade	10	Rebel	10
Jyro X/UP	8	Walkure/Rune	10
Jazz	8		
Shadow	10		

YAMAHA			
BJ	*6	8 Artesia	10
BW'S series	*6	8 Gear/Gear C/Gear News	8
DT series	10	Grand Axis 100	*6 8
FZX	10	Grand Majesty250/400	10
R1-Z	10	Cygnas 125/X	*6 8
SR400	10	Jog series	*6 8
MT-01	10	Zeal	10
SRV	10	Serrow225WE/250	10
SRX250/400/600	10	Dragster series	10
TDM850/900	10	Tricker	10
TT series	10	Virago series	10
TW series	10	Vino series	8
TZR125	10	Blonco	10
V-MAX	10	Maxam	10
XJR400/1200/1300	10	Majesty 125	*6 8
XT600E	10	Majesty 250	10
XT250X	10	Mint	8
XV	10	Mate/News Mate/Town Mate	8
YB-1 (58E2)	10	Lanza	10
YB-1 (58E4-E-5)	8	Renaissa	10
YB50 (6V type)	8	Roadster series	10
YB50 (12V type)	10	Royalster series	10
YB-1 four	8		
Axis sireis	*6	8	
Aprio/Aprio Natural	*6	8	

Remarks

For those mirrors such as Baren Classic, Baren TT, Baren AA, Napoleon Motarz, the mirror housing may touch the reservoir tank. In such case, the position of mirror housing must be arranged so that it does not touch the reservoir tank by using height adjust screw or straight turner.

- *1 Make sure if the right fixing screw is of clockwise or counter clockwise.
- *2 It is likely that fixing screw of body side is 10mm clockwise and mirror side fixing damper screw is 8mm counter clockwise. In such case fix mirror to 8mm counter clockwise screw or use mirror with turner or use straight turner then mirror.
- *3 Depending on production year, 10mm clockwise screw for body side and 10mm counter clockwise screw for mirror side are implemented. Fix replacement mirror to 10mm counter clockwise screw or use mirror with turner to 10mm clockwise screw to body side or use straight turner to 10mm clockwise screw to body side.
- *4 Depending on production year, 10mm clockwise screw for body side and 10mm counter clockwise screw for mirror side are implemented. Fix replacement mirror to 10mm counter clockwise screw or use mirror with turner to 10mm clockwise screw to body side or use straight turner to 10mm clockwise screw to body side. (Mirror lock nut may not be screwed if the fixing screw to body is located deep in the cowl.)
- *5 Depending on production year, 10mm or 8mm clockwise screw and counter clockwise 8mm screw to mirror side is used. Fix replacement mirror to 8mm screw to mirror side.
- *6 Mirror lock nut can not be tightened because the fixing screw hole is covered by body cover.

Suzuki			
Model	mm	Model	mm
DR series	10	Verde	8
DR-Z400SM	10	Wolf50	8
GN125	10	Wolf125/200/250	10
GSX/GSF	10	Epo PV50	8
GSX250FX	10	Katana series	10
GS50	8	Grass Tracker/Bigboy	*4 10
K series	8	Goose250/350	10
RG50y	8	Colleda Sports	8
RMX series	10	Savage series	10
ST250	10	Djebel	10
SV series	10	Skywave250/250SS/400	10
TS series	10	Street Magic	10
VanVan200	10	Sepia series	*6 8
VS1400	10	Choinori series	8
XF650 Free Wind	10	Desperado series	10
ZZ	*6	8 Bandit series	10
250SB	8	8 Birdy series	8
Avenis150/125	8	8 Volty series	10
Address series	*6	8 Marauder series	10
AddressV50/V50G	*4*6	10 MOLLET	8
Inazuma series	10	Let's	*6 8
Intruder series	*4	10 Let's4 series	*6 8
Vecster 150/125	*6	8	

Kawasaki			
ER-6n	10	ESTRELLA	10
D-Tracker	8	Epsilon150	8
KDX series	8	Epsilon250	10
KH series	10	Eliminator series	10
KLE series	10	Xanthus	10
KLX series		SUPER SHERPA	8
KLR650	8	ZEPHYR series	10
KSR-I/II/110	10	BALIUS series	10
W650/400	8	Vulcan series	10
ZRX series	10		
ZR-7	10		
Z750/1000	10		
250TR	10		

Kymco		PGO	
Right mirror has counter clockwise screw so use counter clockwise mirror adapter or counter clockwise mirror.			
KCR125	10	Alloro125	*6 8
Looker 50	*6	8 G-Max150	*6 8
Sooner50SS	*6	8 I-Charge125	*6 8
Sooner100Z	*6	8 My BuBu125α	*6 8
Siper9s	*6	8 PMX110/50	*6 8
Top Boy100/50 OFF	8	8 Road Show50	*6 8
V-Link125RC	*6	8 T-Rex150/125	*6 10
V-Link125S	*6	8	*6

Others			
Ducati Monster series	10		
Triumph Speedo Tripple	10		
MotoGuzzi California EV	10		

Right side is of counter clockwise screw.

